



Mini Rail

Driven

PRODUCT OVERVIEW

The lead screw driven Mini Rail (MR-LS) system maintains all of the great features and benefits of Mini Rail. The system is a fully interchangeable and economical solution to industry standard linear guides, and contains no rolling elements which avoids catastrophic failure.

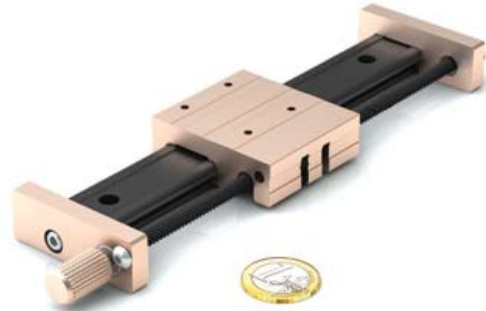

[Link to Mini Rail Lead Options](#)

FEATURES & BENEFITS

- Right hand rolled thread
- 304 stainless steel screw with PTFE coating
- Self-lubricating Polyacetal, anti-backlash nut
- Lengths up to 640 mm
- Eight (8) leads available - see page 22

ACCESSORIES

- NEMA 17 motor mount kit
- Hand brake
- Knob

[Email an Application Engineer](#)

DIMENSIONS

MR15LS

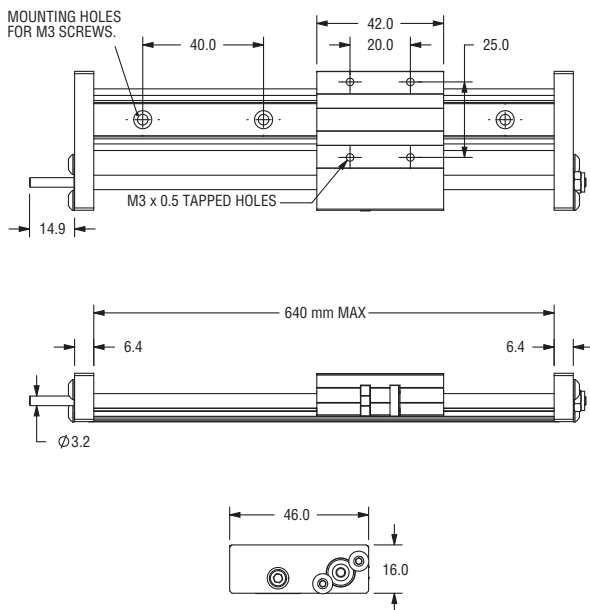

MR20LS

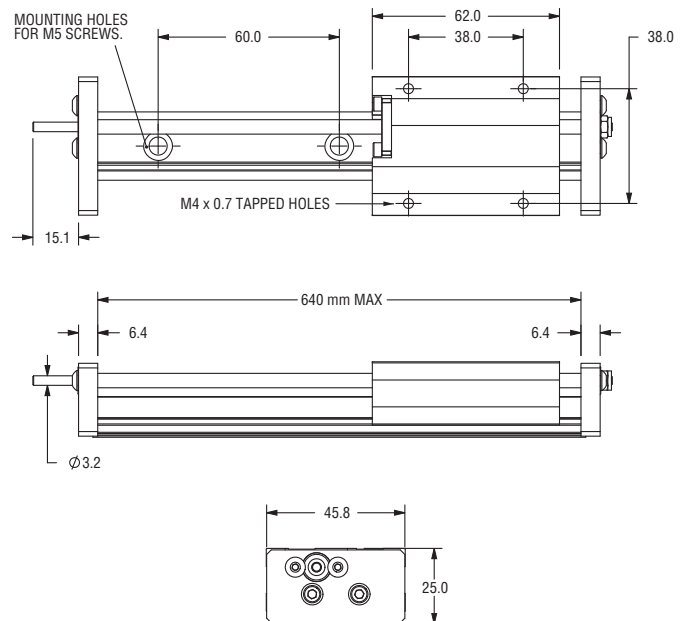

Note: Maximum length for lead screw driven MR is 640 mm.

MINI-RAIL
LP MINI-RAIL
LP UNI-GUIDE
UNI-GUIDE
MINI-RAIL
UNI-GUIDE
LP UNI-GUIDE
DRIVEN SYSTEMS



Driven

Mini Rail

PRODUCT OVERVIEW

The Lead Screw Driven Mini Rail with the attached motor brings another great feature forward in linear motion. Also equipped with all the great features of Mini Rail, this low cost option is equipped with a high torque stepper motor (NEMA 17).



FEATURES & BENEFITS

- Low cost
- High torque single stack stepper motor 42 mm (NEMA 17)
- Robust design - outstanding reliability
- 304 stainless steel screw with PTFE coating
- Fewer parts - less maintenance
- Integral screw for MR20 (coupling used for MR15)
- Ball bearing supports in the end blocks
- Preloaded Polyacetal, anti-backlash nut
- Lengths up to 640 mm
- Eight (8) leads available - see page 22



[Link to Mini Rail Lead Options](#)



[Email an Application Engineer](#)

DIMENSIONS

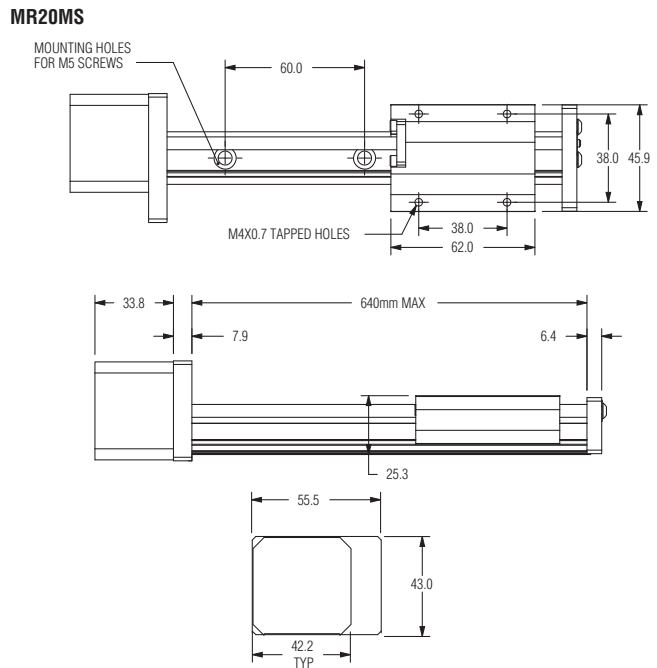
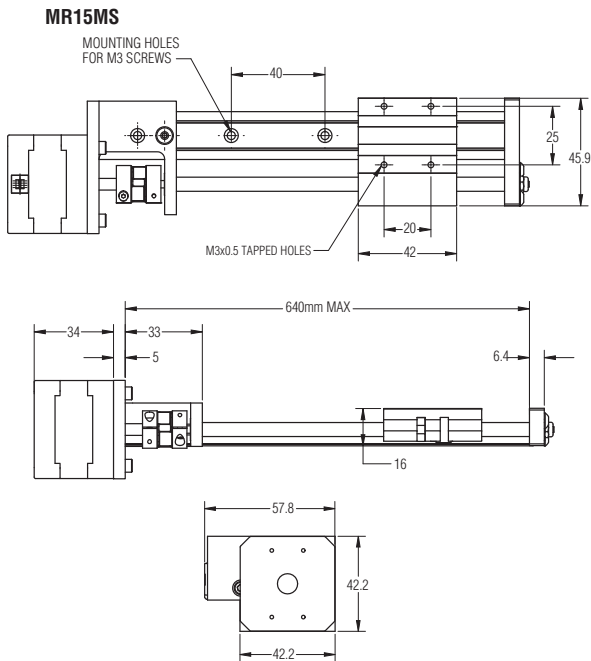

Note: Maximum length for lead screw driven MR is 640 mm.

MINI-RAIL

LP MINI-RAIL

COMPONENTS

LP UNI-GUIDE

UNI-GUIDE

MINI-RAIL

DRIVEN SYSTEMS

UNI-GUIDE

LP UNI-GUIDE



Mini Rail

Driven

STATIC LOAD DATA

The numbers below are for rails in a static condition. Refer to the calculations below to establish dynamic parameters.

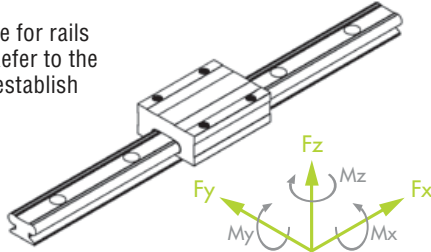

F N	MSL N*
3559	6005
*Max. Static Load in Newtons	

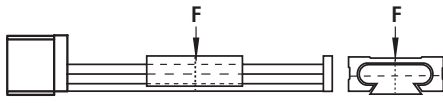

F N
578

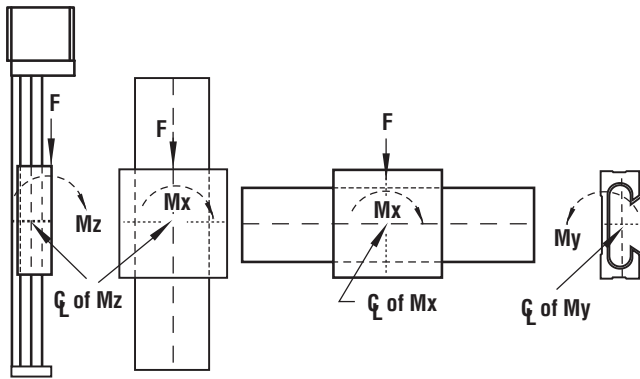
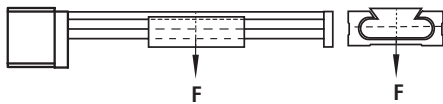

F N	MX N-M	MY N-M	MZ N-M
1112	14.7	24.9	14.7

SIZE 17 STEPPER MOTOR WITH 6 MM (0.236") SCREW

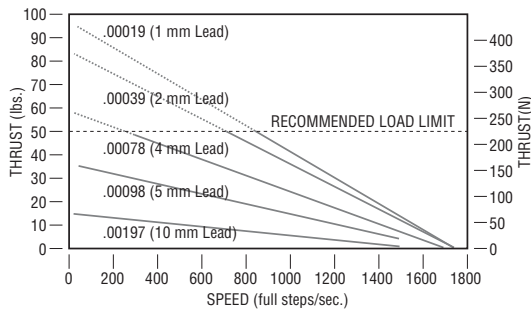

PERFORMANCE RATINGS FOR LINEAR MOTION

Plain bearings are rated by their limiting PV, which is a combination of load over a given surface area and the velocity.

BEARING MATERIAL	MAX. PV	MAX. P	MAX. V NO LUBRICATION
FrelonGOLD®	20,000 (psi x ft./min.) or 0.7 N/mm ² x m/s	3000 psi or 20.68 N/mm ²	300 sfm or 1.524 m/s

PV = The performance measurement of plain bearings
 PV = P x V where P = pressure (load) in psi (kgf/cm²)
 V = velocity (speed) in sfm (m/min.)

Note: All three parameters must be met by an application for the bearing to perform properly.

CANTILEVERED LOADS

Binding of the carriage will occur if the 2:1 ratio for cantilevered loads and drive forces is exceeded. This principle is not load or force dependent. It is a product of the coefficient of frictions associated with plain bearings. Contact factory or website for additional information.

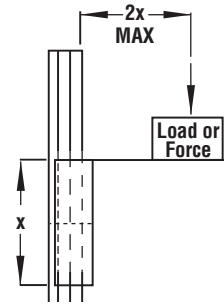

LOAD/MOMENT CONVERSION

$N = 4.45 \times (\text{lbs.})$
 $N\text{-m} = 0.113 \times (\text{in-lbs.})$

LEAD	LEAD CODE	LINEAR TRAVEL PER STEP	
		MM	INCH
1 mm	AH	0.005	0.000197
2 mm	AG	0.010	0.000394
4 mm	AR	0.020	0.000787
5 mm	AX	0.025	0.000984
6 mm	BG	0.030	0.001181
8 mm	BH	0.040	0.001575
10 mm	AJ	0.050	0.001969
12 mm	BD	0.060	0.002362

Note: 1.8° = 200 steps per revolution



Driven

Mini Rail

ORDERING INFORMATION

LEAD SCREW DRIVEN

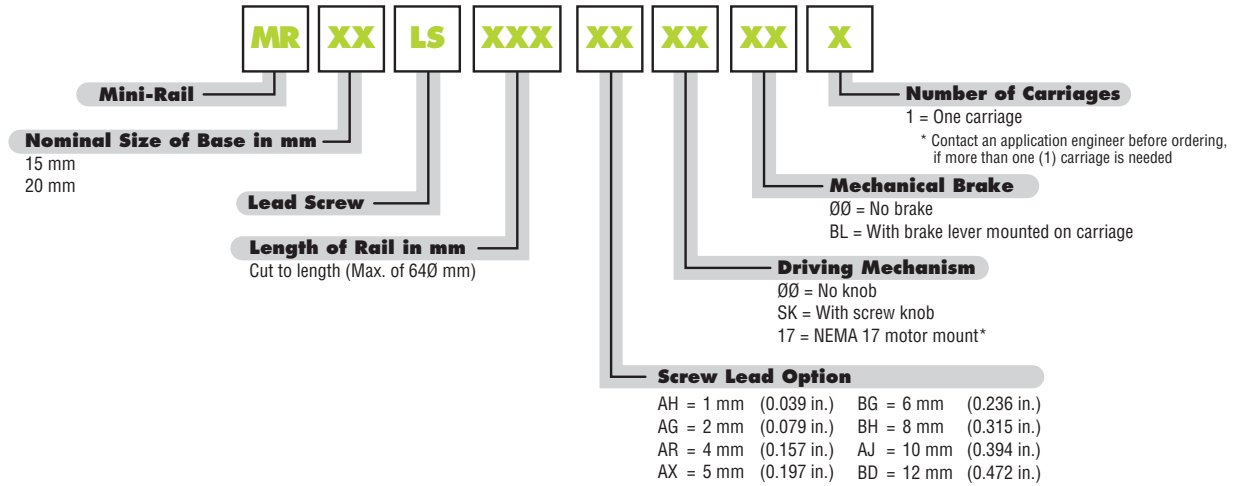

Note: Coupling not included; PBC Recommends R+W EKL2 Coupling or equivalent.
Actuator requires 3.18 mm (.125" bore)

LEAD SCREW DRIVEN WITH MOTOR

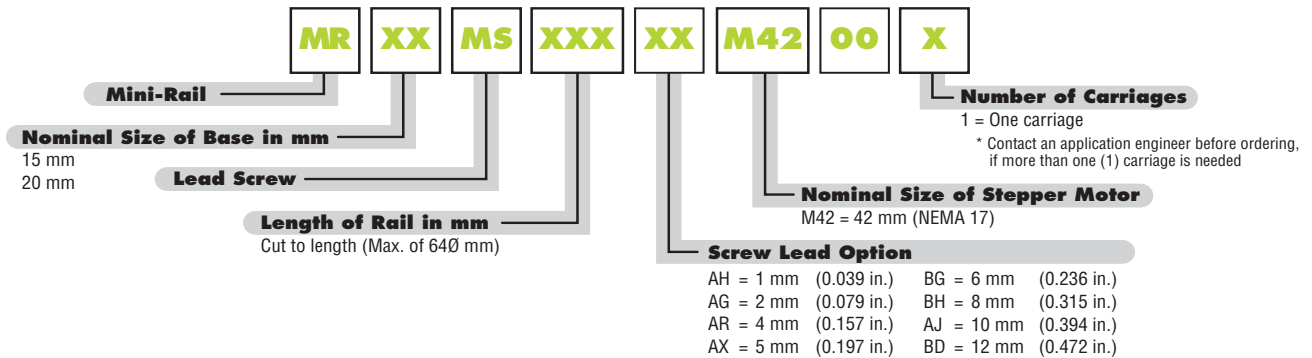

MINI-RAIL
LP MINI-RAIL
LP UNI-GUIDE
UNI-GUIDE
MINI-RAIL
UNI-GUIDE
LP UNI-GUIDE

COMPONENTS
DRIVEN SYSTEMS



Plain Bearings

Frelon® Material

TEMPERATURE

GST linear guides can operate in a wide range of temperatures (-400°F/+400°F) (-240°C /+204°C).

- Maintains the same performance characteristics
- The thin liner allows heat to dissipate through the carriage

THERMAL EXPANSION

The standard bearing clearance options are designed for use in most industrial applications.

For temperatures below 0° F, the Standard I.D. is recommended.

For extreme high temperatures, Mini Rail offers the Compensated I.D. which is recommended for the increased running clearance.

CAUTION *It is always best to inspect actual size at extreme temperatures to insure proper running clearance.*

VACUUMS/OUTGASSING/CLEANROOMS

Due to self-lubrication, low outgassing, and a minimum of particulate (buildup), the carriages are excellent in clean rooms and vacuums.

Testing has been done on the Frelon® materials in accordance with ASTM E-595-90 with acceptable maximums of 1.00% TML and .10% CVCM.

MATERIAL	%TML	%CVCM
FrelonGOLD®	0.00	0.00

TML = Total Mass Loss
CVCM = Collected Volatile Condensable Materials

WASHDOWN & SUBMERGED APPLICATIONS

GST linear guides will provide excellent performance in a washdown or submerged condition.

The linear guide will employ the fluid as a lubricant showing increased velocities and wear life. Oils and non-salt water are especially effective.

Note: Please contact manufacturer before utilizing units with the FrelonGOLD liner for submerged applications.

Temperature Extremes

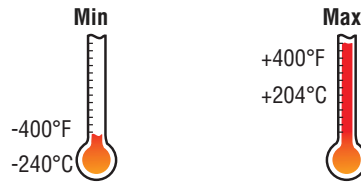

Precision Series
.025 - .051 mm
Running Clearance
(CERAMIC COATED)

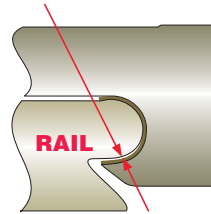

Compensated Series
.064 - .089 mm
Running Clearance
(CERAMIC COATED)

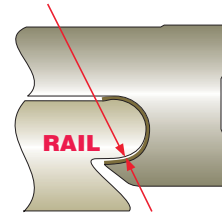

Note: The only GST product that offers the Compensated I.D. is Mini Rail.





Types & Effects of Lubrication

TYPES AND EFFECTS OF LUBRICATION

Lubrication is any outside technique used for reducing the friction, wear, or both of a bearing. **Proper lubrication of carriages is critical.** Evaluate lubrication needs on an application by application basis to determine whether or not it should be used at all, what type is needed, and how it is applied. Below are some criteria on which to base the lubricant decision:

Do not use WD40™, PTFE sprays, or other oils, greases, or sprays that contain fluorocarbons or silicone. In testing, these lubricants have proven to cause long-term stick-slip problems with the Frelon lined carriages. They tend to become a gummy substance that ultimately increases friction.

WD40™ is a registered trademark of the WD40 Corporation.

Recommended Lubricants:

- Waylube oils
- Lightweight oils
- 3-in-1 type oils
- Lightweight petroleum based greases

USING OILS WITH GST UNITS

DO NOT USE ANY TYPE OF MOTOR OIL OR OILS WITH ADDITIVES! These types of oils work well short term, but quickly become ineffective, and will cause stick-slip reactions. As a rule of thumb, the less additives in the oil, the better the performance. Recommended oils are Mobil Vactra #2 (a way lube oil) and any standard 3-in-1 oil. The 3-in-1 oils are tremendous cleaning oils and are the best in preparing for a proper transfer of teflon to the rail.

Plain Bearings

GREASE PRODUCTS

DO NOT USE A MOLY FILLED OR OTHER TYPE FILLED GREASES! They become like a lapping compound and increase wear dramatically.

PROPER USE OF GREASES

Proper use of grease is critical for trouble-free operation.

If a felt wick is present, be sure it is removed because grease inserted into the carriage will cause the wick to act like a brake.

Do not fill all of the running clearance with grease!

The temptation is to treat it like a rolling element and fill it until it weeps from the end. This will cause greater friction and binding.

The rule of thumb for the carriage liner that “thin is better” applies to the use of grease also.

If grease is used and does not work in the application, it is possible to salvage the carriage with minimal work and to continue to operate. Follow the steps below:

1. If possible, remove the carriage from the rail, wipe the grease from the liner, use a 3-in-1 type oil to clean the excess remaining grease, and reinstall.
2. If it is not possible to remove the carriage, wipe as much grease as possible away from the ends, then start to add a 3-in-1 type oil for cleaning the liner. If there is a Zerk hole, apply forced air to the carriage to speed the cleaning process and continue using oil lubrication.



Plain Bearings

Cantilevered Loads

CANTILEVERED LOADS

- Maximum 2:1 ratio
- 1x = carriage separation on same rail
- 2x = distance from rail to load or force

Example: If 2x equals 10" then 1x must be at least 5"

Binding will occur if the 2:1 ratio is exceeded!!

CAUTION This principle is NOT load dependent! It is NOT due to edge loading. It is also NOT dependent on the driving force used! The carriages will bind whether hand or mechanically driven. This principle is a product of friction.

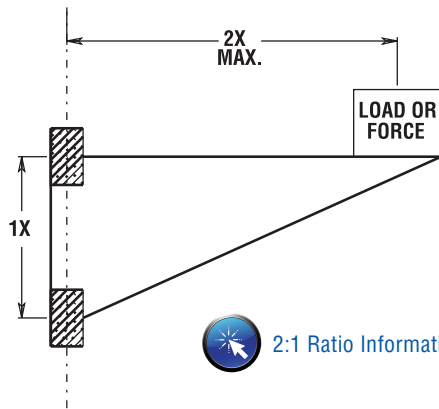

2:1 Ratio Information

Working through the following equation will explain why this is a product of friction:

- P = force being applied
- L = distance out from rail that P is being applied
- s = center to center spacing of carriage
- f = resultant force on carriage by rail
- F = friction force on each carriage
- μ = coefficient of friction (about .25 when not moving)

Balance the moments: $f * s = L * P$
 $L / s = f / P$

Compute friction force: $F = f * \mu$

Note: Total friction force pushing up is $2 * F$. To lock up the slide, the total friction force must be equal to (or greater than) P.

$$P = 2 * F = 2 * f * \mu$$

Substitute for P:

$$L / s = f / (2 * f * \mu) = 1 / (2 * \mu) \Rightarrow L / s = 1 / (2 * \mu)$$

Note: The forces drop out of the equation

Assume static coefficient of friction is .25 ($\mu = .25$) then $L / s = 2$ That is the 2:1 ratio.

There may be other factors that add to the braking effect, but the coefficient of friction is the main cause.

Note: Proper lubrication can help to drop friction and extend the 2:1 ratio.

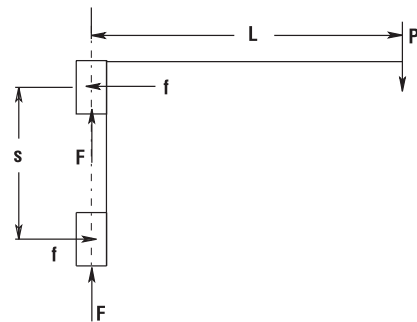



Cantilevered Loads

COUNTERBALANCE

If holding the 2:1 ratio is not possible, one method of preventing binding problems is using a counter balance.

Use the number of bearing pads or surfaces within a carriage and determine spacing based on the length of the carriage.

For efficient counter balances in horizontal applications, use this formula: $M * Y = W * Z$

Note: To avoid problems when running without mass:

$$(M) Z = 1-1/2 s$$

- W can be calculated. Load on bearing will be:

$$\frac{M + W}{\text{\# of carriage}}$$

Example: $50 * 24 = W * Z$ ($Z = 1-1/2 * 6 = 9$)

$$W = \frac{50 * 24}{9} = 133 \text{ lbs.}$$

Load per bearing: $\frac{50 + 133}{4} = 45.75 \text{ lbs. / bearing}$

Cantilever Loads and Drive Force Location without Counterbalance

- d = distance from shaft to Drive Force
- l = distance from shaft to the load center of gravity
- s = center to center spacing of the carriage on the rail (If non-self-aligning, then outside to outside distance should be used.)
- L = $l / s =$ Load Force Ratio
- D = $d / s =$ Drive Force Ratio

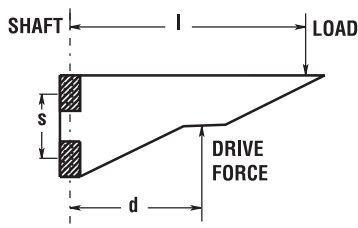

Hanging or "Top Heavy" Horizontal Applications with High Acceleration Rates:

If your application will have high acceleration forces, use this formula for the value of the Drive Force Ratio:

$$D = 0.8 * L * \sqrt{a}$$

where a is acceleration in g's.

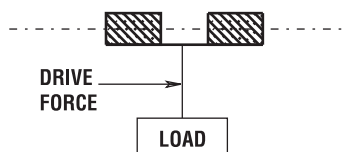

Plain Bearings

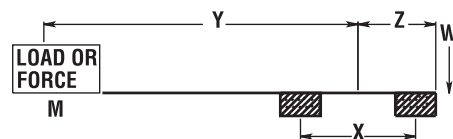
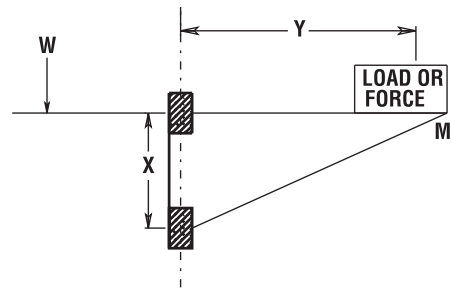

EXAMPLE:

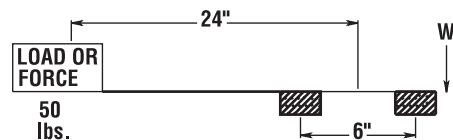

General Rules:

1. Drive Force Ratio (D) should never be larger than 2. A Drive Force Ratio (D) larger than 2 can cause the slide to lock up.
2. Load Force Ratio (L) can be larger than 2, but as this ratio increases, the drive force required to move the slide increases dramatically. A Load Force Ratio (L) larger than 4 is not recommended.
3. If the slide is occasionally operated unloaded, use the distance to the slide's center of gravity as the distance to the load (l).

Vertical Applications:

1. If L is between 0 and 2, the lowest drive forces occur when the value of D is about 90% of L ($D = .9 * L$). However, D values between 0 and L will work fine.
2. If L is between 2 and 4, use this equation: $D = 4 - L$

Horizontal Applications:

For best results, the drive force should be applied as close to the shaft as possible no matter what the value of the Load Force Ratio (L) is.