

(1) Non-interchangeable type

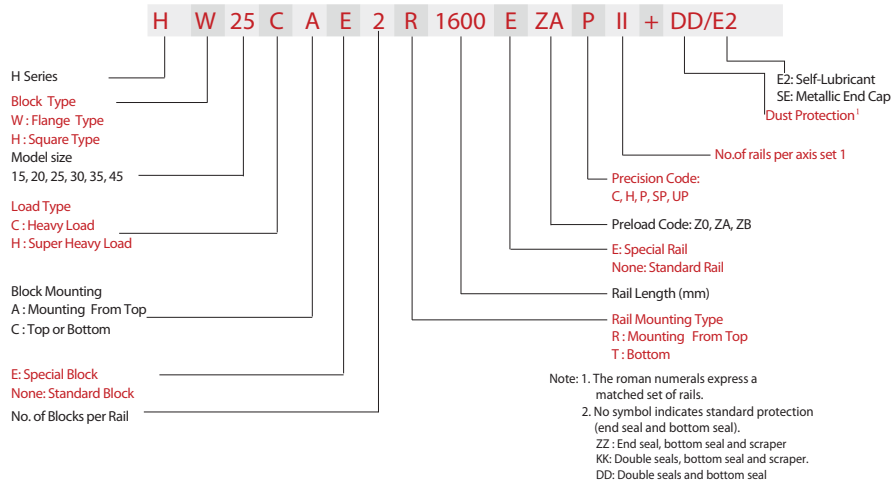

(2) Interchangeable type

○ Model Number of H Block

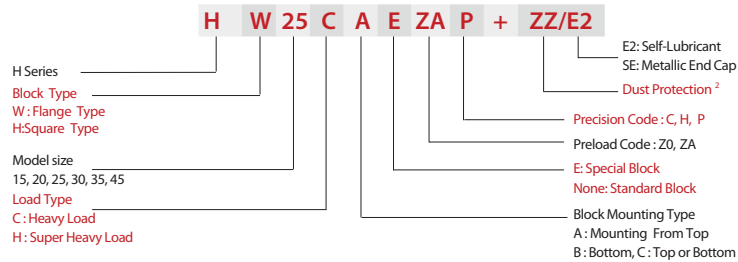

2-1-4 Types

(1) Block types

There're two types of blocks: flange and square. The flange type is suitable for heavy moment load application because of the lower assembly height and wider mounting surface.

Table 2-1-1 Block Types

Type	Model	Shape	Height (mm)	Rail Length (mm)	Main Application
Square	HH-CA		28	100	<ul style="list-style-type: none"> Machine Centers NC Lathes Grinding Machines Precision Machining Machines Heavy Cutting Machines
	HH-HA		90	4000	
Flange	HW-CA		24	100	<ul style="list-style-type: none"> Automation Devices Transportation Equipment Measuring Equipment Devices Requiring High Positional Accuracy
	HW-HA		90	4000	
	HW-CC		24	100	
	HW-HC		90	4000	

Linear Guideways - H Series

(2) Rail types

Besides the standard top mounting type, the bottom mounting type is also available.

Table 2-1-2 Rail Types



2-1-5 Accuracy Classes

The accuracy of H series can be classified into normal (C), high (H), precision (P), super precision (SP), ultra precision (UP), five classes. Please choose the class by referring the accuracy of applied equipment.

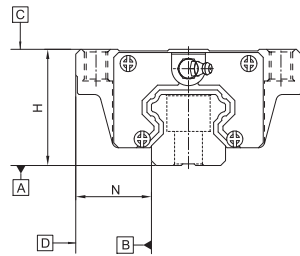

(1) Accuracy of non-interchangeable guideways

Table 2-1-3 Accuracy Standards

Unit: mm

Item	H - 15, 20				
	Normal (C)	High (H)	Precision (P)	Super Precision (SP)	Ultra Precision (UP)
Dimensional tolerance of height H	±0.1	±0.03	0 -0.03	0 -0.015	0 -0.008
Dimensional tolerance of width N	±0.1	±0.03	0 -0.03	0 -0.015	0 -0.008
Variation of height H	0.02	0.01	0.006	0.004	0.003
Variation of width N	0.02	0.01	0.006	0.004	0.003
Running parallelism of block surface C to surface A	See Table 2-1-9				
Running parallelism of block surface D to surface B	See Table 2-1-9				

Table 2-1-4 Accuracy Standards

Unit: mm

Item	H - 25, 30, 35				
	Normal (C)	High (H)	Precision (P)	Super Precision (SP)	Ultra Precision (UP)
Dimensional tolerance of height H	±0.1	±0.04	0 -0.04	0 -0.02	0 -0.01
Dimensional tolerance of width N	±0.1	±0.04	0 -0.04	0 -0.02	0 -0.01
Variation of height H	0.02	0.015	0.007	0.005	0.003
Variation of width N	0.03	0.015	0.007	0.005	0.003
Running parallelism of block surface C to surface A	See Table 2-1-9				
Running parallelism of block surface D to surface B	See Table 2-1-9				

Linear Guideways- H Series

Table 2-1-5 Accuracy Standards

Unit: mm

Item	H-45				
	Normal (C)	High (H)	Precision (P)	Super Precision (SP)	Ultra Precision (UP)
Dimensional tolerance of height H	±0.1	±0.05	0 -0.05	0 -0.03	0 -0.02
Dimensional tolerance of width N	±0.1	±0.05	0 -0.05	0 -0.03	0 -0.02
Variation of height H	0.03	0.015	0.007	0.005	0.003
Variation of width N	0.03	0.02	0.01	0.007	0.005
Running parallelism of block surface C to surface A	See Table 2-1-9				
Running parallelism of block surface D to surface B	See Table 2-1-9				

(2) Accuracy of interchangeable guideways

Table 2-1-6 Accuracy Standards

Unit: mm

Item	H - 15, 20		
	Normal (C)	High (H)	Precision (P)
Dimensional tolerance of height H	±0.1	±0.03	±0.015
Dimensional tolerance of width N	±0.1	±0.03	±0.015
Variation of height H	0.02	0.01	0.006
Variation of width N	0.02	0.01	0.006
Running parallelism of block surface C to surface A	See Table 2-1-9		
Running parallelism of block surface D to surface B	See Table 2-1-9		

Table 2-1-7 Accuracy Standards

Unit: mm

Item	H - 25, 30, 35		
	Normal (C)	High (H)	Precision (P)
Dimensional tolerance of height H	±0.1	±0.04	±0.02
Dimensional tolerance of width N	±0.1	±0.04	±0.02
Variation of height H	0.02	0.015	0.007
Variation of width N	0.03	0.015	0.007
Running parallelism of block surface C to surface A	See Table 2-1-9		
Running parallelism of block surface D to surface B	See Table 2-1-9		

Table 2-1-8 Accuracy Standards

Unit: mm

Item	H - 45		
	Normal (C)	High (H)	Precision (P)
Dimensional tolerance of height H	±0.1	±0.05	±0.025
Dimensional tolerance of width N	±0.1	±0.05	±0.025
Variation of height H	0.03	0.015	0.007
Variation of width N	0.03	0.02	0.01
Running parallelism of block surface C to surface A	See Table 2-1-9		
Running parallelism of block surface D to surface B	See Table 2-1-9		

(3) Accuracy of running parallelism

Table 2-1-9 Accuracy of Running Parallelism

Rail Length (mm)	Accuracy (μm)				
	C	H	P	SP	UP
~ 100	12	7	3	2	2
100 ~ 200	14	9	4	2	2
200 ~ 300	15	10	5	3	2
300 ~ 500	17	12	6	3	2
500 ~ 700	20	13	7	4	2
700 ~ 900	22	15	8	5	3
900 ~ 1,100	24	16	9	6	3
1,100 ~ 1,500	26	18	11	7	4
1,500 ~ 1,900	28	20	13	8	4
1,900 ~ 2,500	31	22	15	10	5
2,500 ~ 3,100	33	25	18	11	6
3,100 ~ 3,600	36	27	20	14	7
3,600 ~ 4,000	37	28	21	15	7

2-1-6 Preload

(1) Definition

A preload can be applied to each guideway. Oversized balls are used. Generally, a linear motion guideway has a negative clearance between groove and balls in order to improve stiffness and maintain high precision. The figure shows the load is multiplied by the preload, the rigidity is doubled and the deflection is reduced by one half. The preload no larger than ZA would be recommended for the model size under H20 to avoid an over-preload affecting the guideway's life.

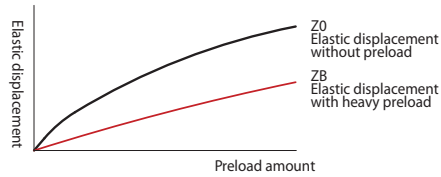

(2) Preload classes

LIMON offers three classes of standard preload for various applications and conditions.

Table 2-1-10 Preload Classes

Class	Code	Preload	Condition	Examples of Application
Light Preload	Z0	0~0.02C	Certain load direction, low impact, low precision required	Transportation devices, auto-packing machines, X-Y axis for general industrial machines, welding machines, welders
Medium Preload	ZA	0.05C~0.07C	High precision required	Machining centers, Z axis for general industrial machines, EDM, NC lathes, Precision X-Y tables, measuring equipment
Heavy Preload	ZB	0.10C~0.12C	High rigidity required, with vibration and impact	Machining centers, grinding machines, NC lathes, horizontal and vertical milling machines, Z axis of machine tools, Heavy cutting machines

Class	Interchangeable Guideway	Non-Interchangeable Guideway
Preload classes	Z0, ZA	Z0, ZA, ZB

Note: The "C" in the preload column denotes basic dynamic load rating.

2-1-7 Lubrication

(1) Grease

- Grease nipple

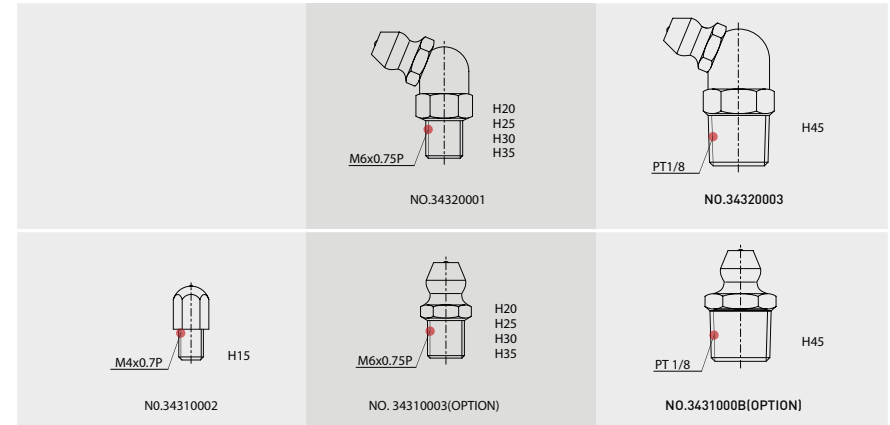

○ Mounting location

The standard location of the grease fitting is at both ends of the block, but the nipple can be mounted at each side of block. For lateral installation, we recommend that the nipple be mounted at the non-reference side, otherwise please contact us. It is possible to perform lubrication by using the oil-piping joint.

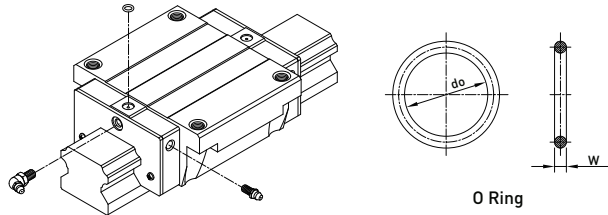

O Ring

Table 2-1-11 O-Ring size and max. permissible depth for piercing

Size	O-Ring		Lube hole at top: max. permissible depth for piercing
	do (mm)	W (mm)	
H15	2.5±0.15	1.5±0.15	3.75
H20	4.5±0.15	1.5±0.15	5.7
H25	4.5±0.15	1.5±0.15	5.8
H30	4.5±0.15	1.5±0.15	6.3
H35	4.5±0.15	1.5±0.15	8.8
H45	4.5±0.15	1.5±0.15	8.2

○ The lubricant amount for a block filled with grease

Table 2-1-12 The lubricant Amount for a Block Filled with Grease

Size	Heavy load (cm ³)	Super heavy load (cm ³)	Size	Heavy load (cm ³)	Super heavy load (cm ³)
H15	1	-	H35	10	12
H20	2	3	H45	17	21
H25	5	6			
H30	7	8			

○ Frequency of replenishment

Check the grease every 100 km, or every 3-6 months.

(2) Oil

The recommended viscosity of oil is about 30~150c St. If customers need to use oil-type lubrication, please inform us.

○ Oil refilling rate

Table 2-1-13

Size	Refilling rate (cm ³ /hr)	Size	Refilling rate (cm ³ /hr)
H15	0.2	H35	0.3
H20	0.2	H45	0.4
H25	0.3	-	-
H30	0.3	-	-

2-1-8 Dust Proof Accessories

(1) Codes of standard dust proof accessories

If the following accessories are needed, please add the code followed by the model number.

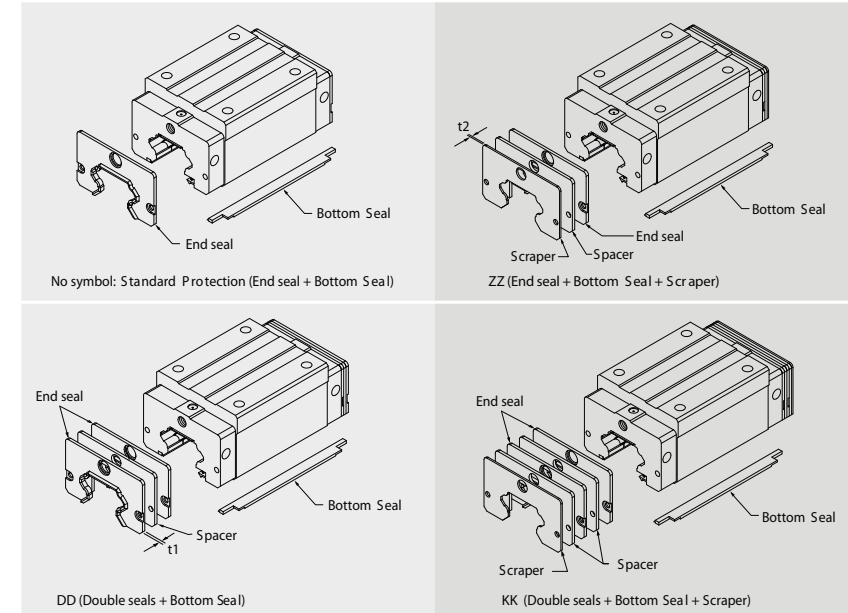

(2) End seal and bottom seal

To prevent life reduction caused by iron chips or dust entering the block.

(3) Double seals

Enhances the wiping effect, foreign matter can be completely wiped off.

Table 2-1-14 Dimensions of end seal

Size	Thickness (t1) (mm)	Size	Thickness (t1) (mm)
H15 ES	3	H35 ES	3.2
H20 ES	3.5	H45 ES	4.5
H25 ES	3.5	-	-
H30 ES	3.2	-	-

(4) Scraper

The scraper removes high-temperature iron chips and larger foreign objects.

Table 2-1-15 Dimensions of scraper

Size	Thickness (t2) (mm)	Size	Thickness (t2) (mm)
H15 SC	1.5	H35 SC	1.5
H20 SC	1.5	H45 SC	1.5
H25 SC	1.5	-	-
H30 SC	1.5	-	-

(5) Codes of high-dust proof accessories

LIMON develops many kinds of dust proof accessories for different application and working environment to avoid dust or debris. If the following accessories are needed, please add the code followed by the model number.

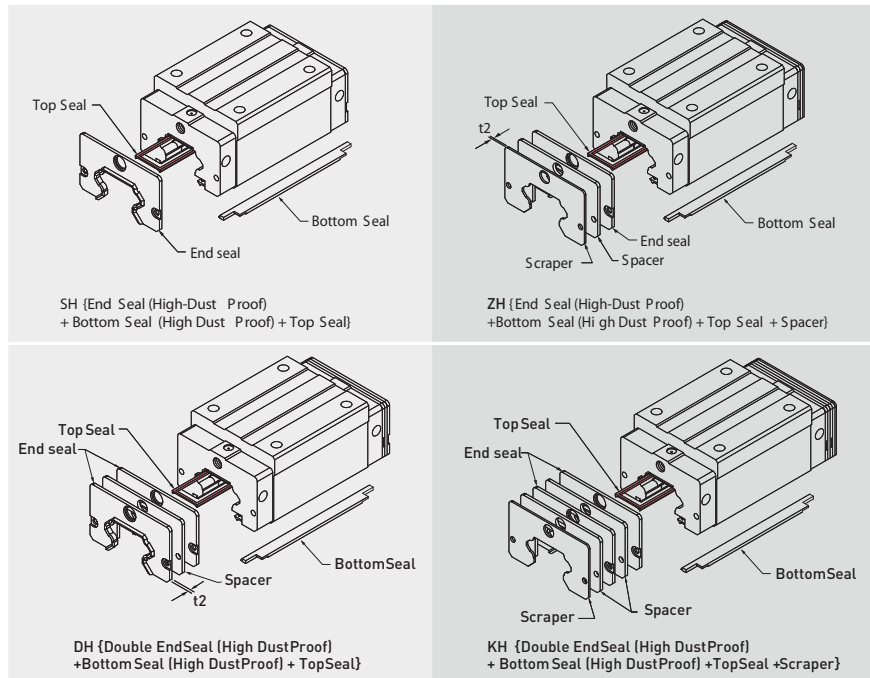

- Note:
1. The available size for high dust proof accessories are H20(C/H), 25(C/H), 30(C/H), 35(C/H) and 45C.
 2. The value of friction force will increase 0.6~1.2 kgf.
 3. For higher demands of the anti-dust ability, please contact LIMON

o Top Seal

Top seal can efficiently avoid dust from the surface of rail or tapping hole getting inside the block.

2-1-9 Friction

The maximum value of resistance per end seal are as shown in the table.

Table 2-1-16 Seal Resistance

Size	Resistance N (kgf)	Size	Resistance N (kgf)
H15	1.18 (0.12)	H35	3.04 (0.31)
H20	1.57 (0.16)	H45	3.83 (0.39)
H25	1.96 (0.2)	-	-
H30	2.65 (0.27)	-	-

Note: 1kgf=9.81N

2-1-10 The Accuracy Tolerance of Mounting Surface

(1) The accuracy tolerance of rail-mounting surface
Because of the Circular-arc contact design, the H linear guideway can compensate for some surface-error on installation and still maintain smooth linear motion.

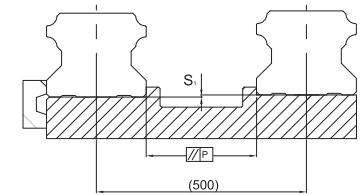

(2) The parallelism tolerance of reference surface (P)

Table 2-1-17 Max. Parallelism Tolerance (P)

unit: μm

Size	Preload classes		
	Z0	ZA	ZB
H15	25	18	-
H20	25	20	18
H25	30	22	20
H30	40	30	27
H35	50	35	30
H45	60	40	35

(3) The accuracy tolerance of reference surface height

Table 2-1-18 Max. Tolerance of Reference Surface Height (S_i)

unit: μm

Size	Preload classes		
	Z0	ZA	ZB
H15	130	85	-
H20	130	85	50
H25	130	85	70
H30	170	110	90
H35	210	150	120
H45	250	170	140

2-1-11 Cautions for Installation

(1) Shoulder heights and fillets

Improper shoulder heights and fillets of mounting surfaces will cause a deviation in accuracy and the interference with the chamfered part of the rail or block. As long as the recommended shoulder heights and fillets are followed, installation inaccuracies should be eliminated.

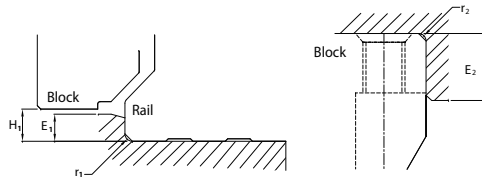

Table 2-1-19 Shoulder Heights and Fillets

Size	Max. radius of fillets r_1 (mm)	Max. radius of fillets r_2 (mm)	Shoulder height of the rail E_1 (mm)	Shoulder height of the block E_2 (mm)	Clearance under block H_1 (mm)
H15	0.5	0.5	3	4	4.3
H20	0.5	0.5	3.5	5	4.6
H25	1.0	1	5	5	5.5
H30	1.0	1	5	5	6
H35	1.0	1	6	6	7.5
H45	1.0	1	8	8	9.5

(2) Tightening Torque of Bolts for Installation

Improper tightening of bolts will seriously influence the accuracy of Linear Guideway installation. The following tightening torques for different sizes of bolts are recommended.

Table 2-1-20 Mounting Torque

Size	Bolt size	Torque N-cm (kgf-cm)		
		Iron	Casting	Aluminum
H15	M4×0.7P×16L	392 (40)	274 (28)	206 (21)
H20	M5×0.8P×16L	883 (90)	588 (60)	441 (45)
H25	M6×1P×20L	1373 (140)	921 (94)	686 (70)
H30	M8×1.25P×25L	3041 (310)	2010 (205)	1470 (150)
H35	M8×1.25P×25L	3041 (310)	2010 (205)	1470 (150)
H45	M12×1.75P×35L	11772 (1200)	7840 (800)	5880 (600)

2-1- 12 Dimensions for LIMON H Series

(1) HH-CA / HH-HA

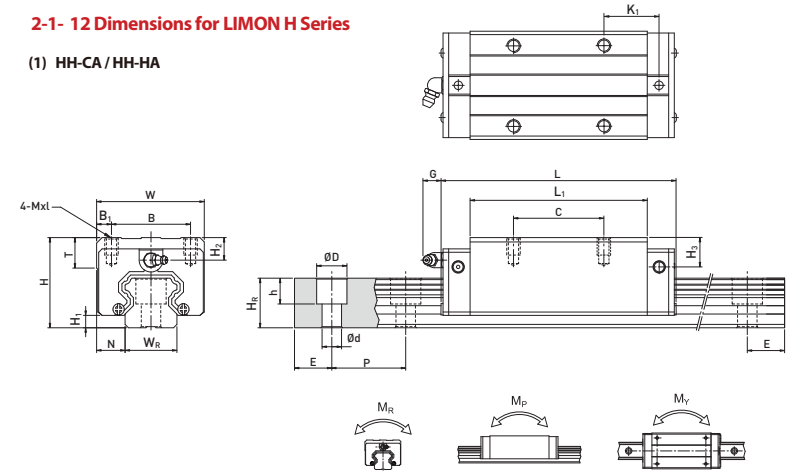

ModelNo.	Dimensions of Assembly (mm)		Dimensions of Block (mm)										Dimensions of Rail (mm)					Mounting Bolt for Rail	Basic Dynamic Load Rating C_0 (kN)	Basic Static Load Rating C_1 (kN)	Static Rated Moment			Weight						
	H	H ₁	N	W	B	B ₁	C	L ₁	L	K ₁	G	Mxl	T	H ₂	H ₃	W _e	H _e				D	h	d	P	E	M _R	M _P	M _V	Block	Rail
	mm	mm	mm	mm	mm	mm	mm	mm	mm	mm	mm	mm	mm	mm	mm	mm	mm				mm	mm	mm	mm	mm	mm	kN-m	kN-m	kN-m	kg
HH15CA	28	4.3	9.5	34	26	4	26	39.4	61.4	10	5.3	M4x5	6	7.95	7.7	15	15	7.5	5.3	4.5	60	20	M4x16	11.38	16.97	0.12	0.10	0.10	0.18	1.45
HH20CA	30	4.6	12	44	32	6	36	50.5	77.5	12.25	12	M5x6	8	6	6	20	17.5	9.5	8.5	6	60	20	M5x16	17.75	27.76	0.27	0.20	0.20	0.30	2.21
HH20HA							50	65.2	92.2	12.6																				
HH25CA	40	5.5	12.5	48	35	6.5	35	58	84	15.7	12	M6x8	8	10	9	23	22	11	9	7	60	20	M6x20	26.48	36.49	0.42	0.33	0.33	0.51	3.21
HH25HA							50	78.6	104.6	18.5																				
HH30CA	45	6	16	60	40	10	40	70	97.4	20.25	12	M8x10	8.5	9.5	13.8	28	26	14	12	9	80	20	M8x25	38.74	52.19	0.66	0.53	0.53	0.88	4.47
HH30HA							60	93	120.4	21.75																				
HH35CA	55	7.5	18	70	50	10	50	80	112.4	20.6	12	M8x12	10.2	16	19.6	34	29	14	12	9	80	20	M8x25	49.52	69.16	1.16	0.81	0.81	1.45	6.30
HH45CA	70	9.5	20.5	86	60	13	60	97	139.4	23	12.9	M10x17	16	18.5	30.5	45	38	20	17	14	105	22.5	M12x35	77.57	102.71	1.98	1.55	1.55	2.73	10.41

Note : 1 kgf = 9.81 N