

C197

SOLID CONTROL HANDWHEEL WITH REVOLVING HANDLE



Materials:

Reinforced and stabilized polyamide.
Resistant to oils and greases.

Surface finish:

Satin.

Colour:

Black (RAL 9011).

Central cap:

Grey polyamide (RAL 7035). 13.

Alternative cap colours:

Orange (RAL 2004 code 02).
Blue (RAL 5015 code 07).
Yellow (RAL 1021 code 10).
Red (RAL 3000 code 16).
Green (RAL 6024 code 17).
Black (RAL 9011 code 01).

Main insert:

Galvanised steel insert with smooth through bore (tolerance H10).

Lateral insert:

Brass insert with threaded through hole.

Lateral handle:

C197: Revolving handle art. M144 (page).
C193: Revolving handle art. M145 (page).
C194: Revolving handle art. M129 (page).
C195: Revolving handle art. M202 (page).

Fixing method:

For fixing systems, or execution of keyways or square holes, please refer to the technical notes attached to the catalogue [page].

Special requests:

- On request and with a minimum of 50 pieces, the inserts can be supplied with the hole d1 with H7 tolerance and black-oxide finish. Add the letters ZB to the standard code. Example: C197100.TD1001PZB.
- Upon request and for special quantities inserts can be supplied with custom hole diameter d1.
- Upon request and for special quantities inserts can be supplied in different materials/with different coatings.
- Upon request and for special quantities handwheels, handles and caps are available in the colours indicated in the chart (reduced range) [page].

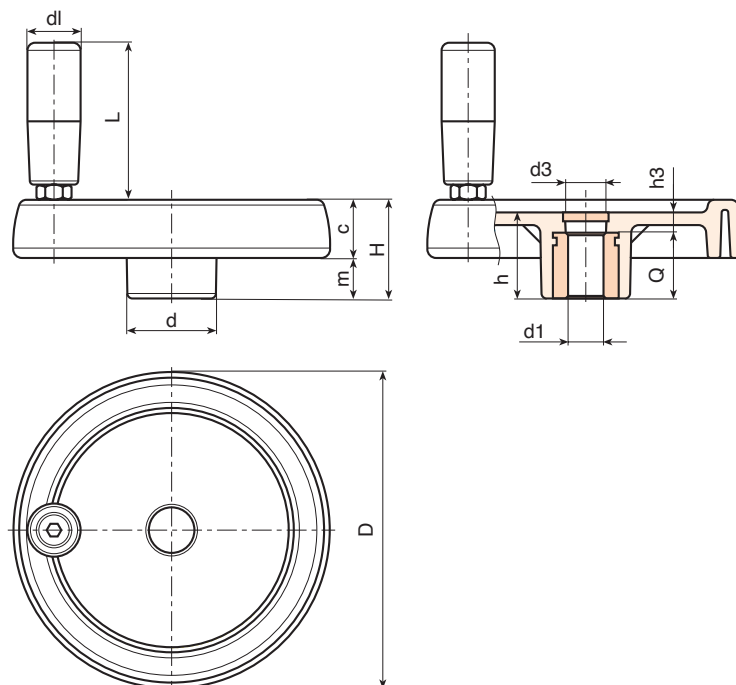

| Code | Art. | D | H | h | d | m | c | d3 | h3 | Dm | d1 _{H10} | Q | g |
|------|-----------------|-----|----|----|----|------|------|----|----|----|-------------------|----|------|
| - | C197080.TP0501P | 81 | 33 | 29 | 25 | 16 | 17 | 16 | 9 | 12 | 5 | 20 | 130 |
| - | C197080.TD0801P | 81 | 33 | 29 | 25 | 16 | 17 | 16 | 9 | 12 | 8 | 20 | 129 |
| - | C197080.TD1001P | 81 | 33 | 29 | 25 | 16 | 17 | 16 | 9 | 12 | 10 | 20 | 127 |
| - | C197100.TP0501P | 100 | 39 | 34 | 30 | 18.5 | 20.5 | 16 | 10 | 16 | 5 | 24 | 192 |
| - | C197100.TD0801P | 100 | 39 | 34 | 30 | 18.5 | 20.5 | 16 | 10 | 16 | 8 | 24 | 192 |
| - | C197100.TD1001P | 100 | 39 | 34 | 30 | 18.5 | 20.5 | 16 | 10 | 16 | 10 | 24 | 190 |
| - | C197100.TD1201P | 100 | 39 | 34 | 30 | 18.5 | 20.5 | 16 | 10 | 16 | 12 | 24 | 188 |
| - | C197125.TP0501P | 125 | 44 | 37 | 36 | 20 | 24 | 26 | 13 | 18 | 5 | 24 | 351 |
| - | C197125.TD0801P | 125 | 44 | 37 | 36 | 20 | 24 | 26 | 13 | 18 | 8 | 24 | 345 |
| - | C197125.TD1201P | 125 | 44 | 37 | 36 | 20 | 24 | 26 | 13 | 18 | 12 | 24 | 340 |
| - | C197125.TD1401P | 125 | 44 | 37 | 36 | 20 | 24 | 26 | 13 | 18 | 14 | 24 | 335 |
| - | C197150.TD0801P | 150 | 54 | 44 | 38 | 25 | 29 | 26 | 12 | 22 | 8 | 32 | 588 |
| - | C197150.TD1201P | 150 | 54 | 44 | 38 | 25 | 29 | 26 | 12 | 22 | 12 | 32 | 580 |
| - | C197150.TD1401P | 150 | 54 | 44 | 38 | 25 | 29 | 26 | 12 | 22 | 14 | 32 | 577 |
| - | C197150.TD1601P | 150 | 54 | 44 | 38 | 25 | 29 | 26 | 12 | 22 | 16 | 32 | 570 |
| - | C197175.TD0801P | 173 | 57 | 47 | 40 | 25.5 | 31.5 | 26 | 15 | 22 | 8 | 32 | 770 |
| - | C197175.TD1601P | 173 | 57 | 47 | 40 | 25.5 | 31.5 | 26 | 15 | 22 | 16 | 32 | 755 |
| - | C197175.TD2001P | 173 | 57 | 47 | 40 | 25.5 | 31.5 | 26 | 15 | 22 | 20 | 32 | 751 |
| - | C197200.TD0801P | 202 | 59 | 49 | 44 | 24 | 35 | 27 | 13 | 28 | 8 | 36 | 980 |
| - | C197200.TD2001P | 202 | 59 | 49 | 44 | 24 | 35 | 27 | 13 | 28 | 20 | 36 | 960 |
| - | C197250.TD0801P | 249 | 68 | 58 | 59 | 29 | 39 | 36 | 22 | 28 | 8 | 36 | 1530 |

Attention: For a minimum of 50 pieces the diameter d1 can be customised (hole tolerance H10 galvanised and H7 black-oxide treated).
Dm = Maximum obtainable diameter for subsequent machining (widening).

C193

SOLID CONTROL HANDWHEEL WITH REVOLVING HANDLE M145



| Code | Art. | D | H | h | d | m | c | dI | L | d1H10 | Q | g |
|------|-----------------|-----|----|----|----|------|------|----|----|-------|----|------|
| - | C193080.TP0501P | 81 | 33 | 29 | 25 | 16 | 17 | 20 | 55 | 5 | 20 | 135 |
| - | C193100.TP0501P | 100 | 39 | 34 | 30 | 18.5 | 20.5 | 20 | 55 | 5 | 24 | 220 |
| - | C193125.TP0501P | 125 | 44 | 37 | 36 | 20 | 24 | 23 | 66 | 5 | 24 | 370 |
| - | C193150.TD0801P | 150 | 54 | 44 | 38 | 25 | 29 | 25 | 76 | 8 | 32 | 594 |
| - | C193175.TD0801P | 173 | 57 | 47 | 40 | 25.5 | 31.5 | 25 | 87 | 8 | 32 | 750 |
| - | C193200.TD0801P | 202 | 59 | 49 | 44 | 24 | 35 | 27 | 96 | 8 | 36 | 965 |
| - | C193250.TD0801P | 249 | 68 | 58 | 59 | 29 | 39 | 27 | 96 | 8 | 36 | 1500 |

Attention: For a minimum of 50 pieces the diameter d1 can be customised (hole tolerance H10 galvanised and H7 black-oxide treated).
Dm = Maximum obtainable diameter for subsequent machining (widening).

Lateral handle:
C193: Revolving handle art. M145 (page).

C194

SOLID CONTROL HANDWHEEL WITH REVOLVING HANDLE M129



| Code | Art. | D | H | h | d | m | c | dI | L | d1H10 | Q | g |
|------|-----------------|-----|----|----|----|------|------|----|----|-------|----|------|
| - | C194080.TP0501P | 81 | 33 | 29 | 25 | 16 | 17 | 20 | 52 | 5 | 20 | 145 |
| - | C194100.TP0501P | 100 | 39 | 34 | 30 | 18.5 | 20.5 | 20 | 52 | 5 | 24 | 235 |
| - | C194125.TP0501P | 125 | 44 | 37 | 36 | 20 | 24 | 23 | 62 | 5 | 24 | 350 |
| - | C194150.TD0801P | 150 | 54 | 44 | 38 | 25 | 29 | 25 | 72 | 8 | 32 | 610 |
| - | C194175.TD0801P | 173 | 57 | 47 | 40 | 25.5 | 31.5 | 25 | 81 | 8 | 32 | 755 |
| - | C194200.TD0801P | 202 | 59 | 49 | 44 | 24 | 35 | 27 | 93 | 8 | 36 | 975 |
| - | C194250.TD0801P | 249 | 68 | 58 | 59 | 29 | 39 | 27 | 93 | 8 | 36 | 1520 |

Attention: For a minimum of 50 pieces the diameter d1 can be customised (hole tolerance H10 galvanised and H7 black-oxide treated).
Dm = Maximum obtainable diameter for subsequent machining (widening).

Lateral handle:
C194: Revolving handle art. M129 (page).

C195

SOLID CONTROL HANDWHEEL WITH REVOLVING HANDLE M202



| Code | Art. | D | H | h | d | m | c | dI | L | d1H10 | Q | g |
|------|-----------------|-----|----|----|----|------|------|----|----|-------|----|------|
| - | C195150.TD0801P | 150 | 54 | 44 | 38 | 25 | 29 | 40 | 64 | 8 | 32 | 610 |
| - | C195175.TD0801P | 173 | 57 | 47 | 40 | 25.5 | 31.5 | 40 | 64 | 8 | 32 | 750 |
| - | C195200.TD0801P | 202 | 59 | 49 | 44 | 24 | 35 | 40 | 64 | 8 | 36 | 960 |
| - | C195250.TD0801P | 249 | 68 | 58 | 59 | 29 | 39 | 40 | 64 | 8 | 36 | 1490 |

Attention: For a minimum of 50 pieces the diameter d1 can be customised (hole tolerance H10 galvanised and H7 black-oxide treated).
Dm = Maximum obtainable diameter for subsequent machining (widening).

Lateral handle:
C195: Revolving handle art. M202 (page).